

CAD FILE:

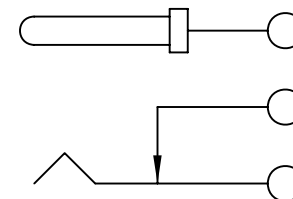

SCHEMATIC

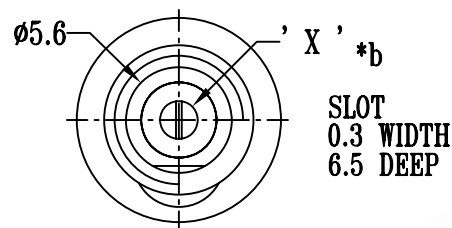
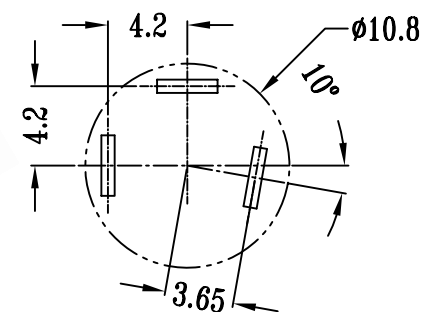
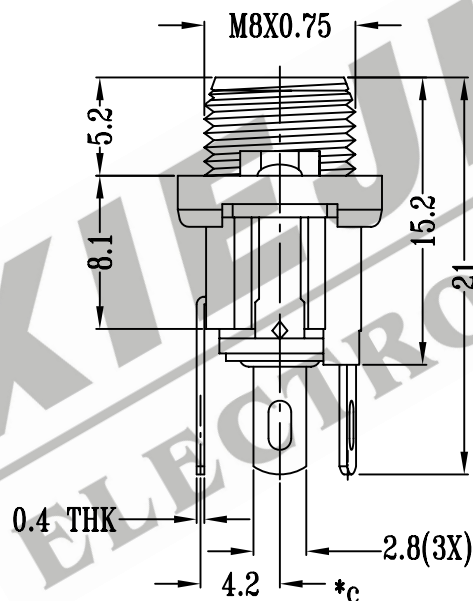
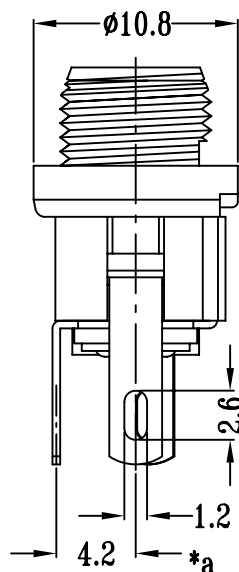

P.C.B LAYOUT

DS-026-A	X=2.5mm
DS-026-B	X=2.0mm
DS-026-A-S	X=2.5mm WITH SLOT
DS-026-B-S	X=2.0mm WITH SLOT

注：“*”表示关键尺寸（6个）

NO.	PARTS	MATERIALS	Q'TY	FINISH	TOLERANCE UNLESS SPECIFIED	SHENZHEN XIEJIA ELECTRONICS CO.,LTD.			
8						TITLE : DC POWER JACK MODEL: DS-026 ALL MATERIALS MUST BE COMPLIANT TO ROHS			
7	CASE	POM	1	BLACK	WITHIN: 1.5±0.1mm OVER : 1.5±0.2mm				
6	PAPER WASHER	HARD PAPER	1	RED		UNIT : mm	DRWG NO.: XJ-DR-DS026-00		
5	SOCKET	BRASS	1	Ni PLATED		SCALE: 5:2	DWN.	ZHOUYU	2004-10-20
4	PLUG PIN	BRASS	1	Ni PLATED		CHK'D	FANGYING	2004-10-20	
3	SPRING TERMINAL B	PBS STRIP	1	Ag PLATED OVER Ni PLATED		APPD.	KANGXINAN	2004-10-20	
2	TERMINAL C	PBS STRIP	1	Ag PLATED OVER Ni PLATED					
1	TERMINAL A	BRASS STRIP	1	Ag PLATED OVER Ni PLATED					